

CONNECTOR INSTALLATION INSTRUCTIONS

Wind-Lok Series

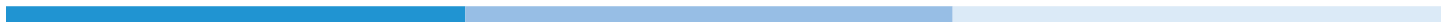

Part 1: Product Composition

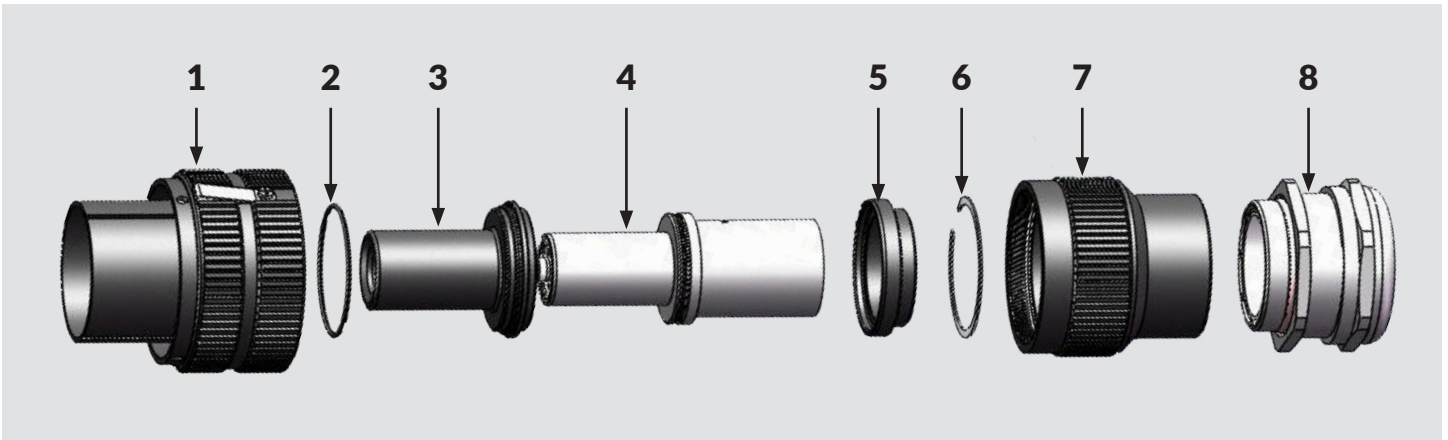

1. Plug Package Contents

- 1: Plug assembly
- 2: O-Ring
- 3: Front insert
- 4: Contact assembly
- 5: Rear insert
- 6: Retaining ring
- 7: Adapter
- 8: Cable gland

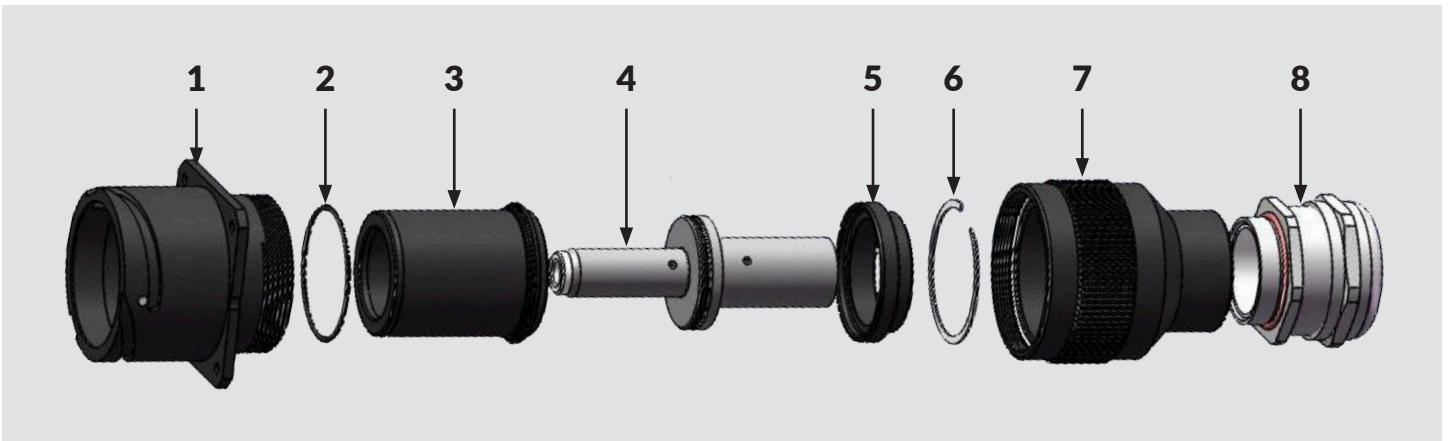

2. Receptacle Package Contents

- 1: Receptacle assembly
- 2: O-Ring
- 3: Front insert
- 4: Contact assembly
- 5: Rear insert
- 6: Retaining ring
- 7: Adapter
- 8: Cable gland

Parts Identification

The pin insert can only be mutually matched with the pin contact, and the socket insert can only be mutually matched with the socket contact. The two can not be confused and installed!



Pin insert

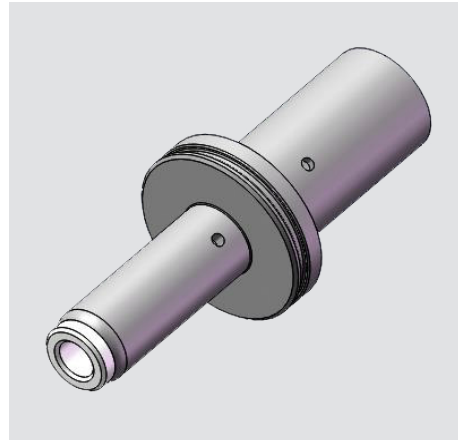

Pin contact

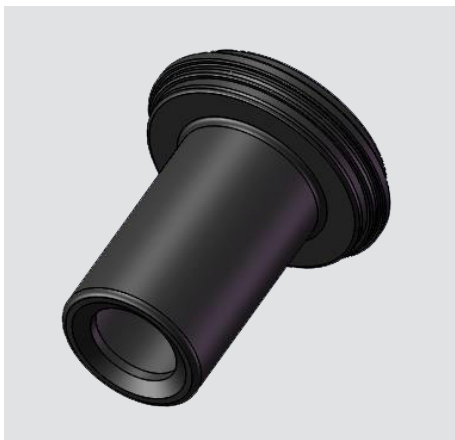

Socket insert



Socket contact

Part 2: Product Assembly

Step 1: Stripping

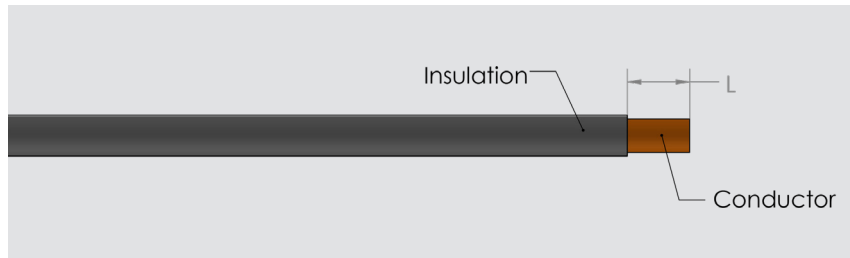

Figure 1

As shown in figure 1, cut the cable according to the stripping length specified by the contact in Table 1. When cutting, ensure that the cut surface of the insulation layer is flush, the cable is not damaged, and the cut surface of the conductor is flush;

Table 1

Corresponding contact stripping length		
Contact Type	Cable Size	Length "L"
1	4/0 AWG-120 SQ MM	29mm
2	262 KCMIL-150 SQ MM	29mm
2b		38mm
3a	313 KCMIL-185 SQ MM	29mm
3b		38mm
4a	373 KCMIL-200 SQ MM	29mm
4b		38mm
5a	444 KCMIL-240 SQ MM	29mm
5b		38mm
6	535 KCMIL	
7	646 KCMIL	
7a	300 SQ MM	
8	777 KCMIL	

Note: The contact type can be obtained by referring to the 8th bit of Wind-Lok coding logic in Appendix 1.

Step 2: Contact crimping

Put the contact on the cut cable until it is completely close to the cable insulation (the contact well and the cable insulation layer should not exceed 1.5mm), and check whether the cable is installed in the correct position through the observation hole of the contact (in the observation hole.) To see the cable conductor, use the corresponding contact crimping tool to crimp the contact (see Appendix 2 for the recommended crimping tool or use other tools). Be careful not to press into the observation hole of the contact when crimping, as shown in Figure 2 below.

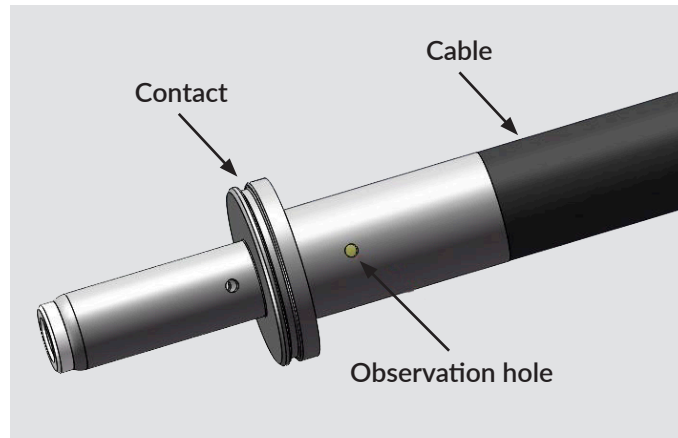

Figure 2

Step 3: Connector assembly

As shown in Figure 3, first put the O-ring on the front insert (for easy identification, the color of the O-ring is changed from the actual black to red), and then install the front insert into the plug/socket assembly.

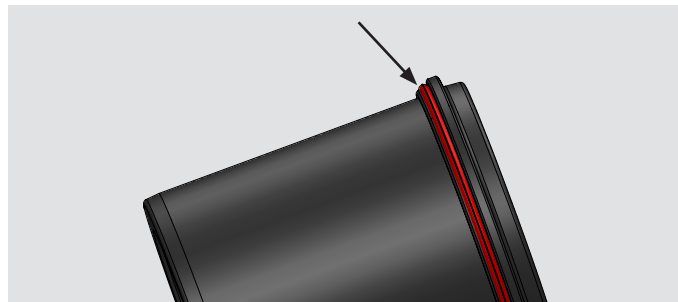

Figure 3

Then, as shown in Figure 4, first put the gland, adapter, retaining ring and rear insert into the cable first, put the crimped cable contact into the front insert and then sleeve the rear insert, and then put the retaining ring Clamp it into the groove of the shell. (as shown in Figure 5, the color of the shell components is changed to yellow for easy identification). In order to confirm that the retaining ring is completely stuck, pull the contact backward to confirm whether the contact can be pulled out. Finally, tighten the adapter and glands respectively installed to complete the assembly.

Note: Please refer to Appendix 3 for the tightening torque of adapter and glands; refer to Appendix 4 for adapter tightening tools.

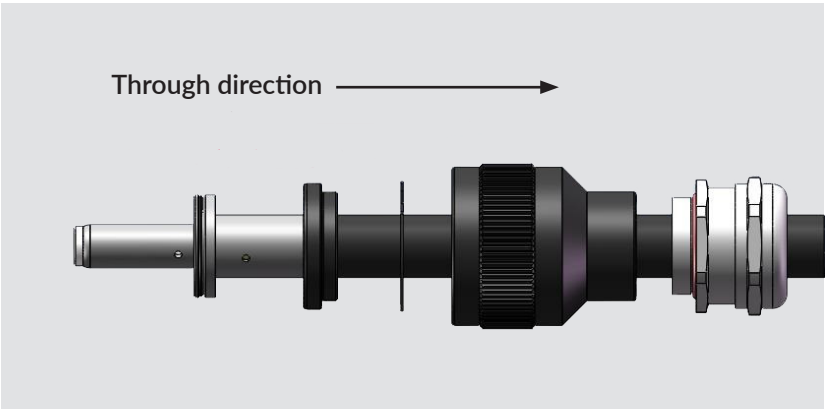

Figure 4

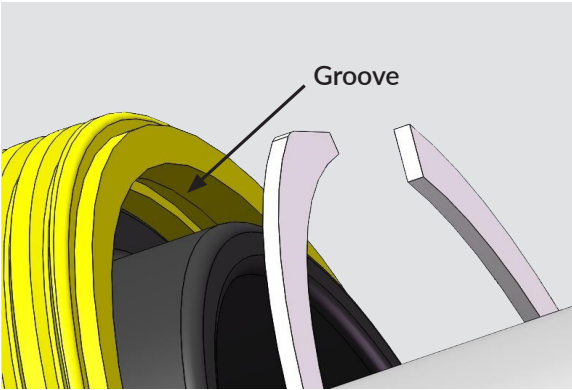

Figure 5

Part 3: Assembly of Gland with EMI Function

As shown in Figure 6 is the M50 gland with EMI function. During the connector installation, the shielding layer needs to be cut for the second part of the first step of stripping. The cutting length of the shielding layer is reserved 15mm to ensure that the shielding layer can contact the reed of the gland, as shown in Figure 7 below.



Figure 6

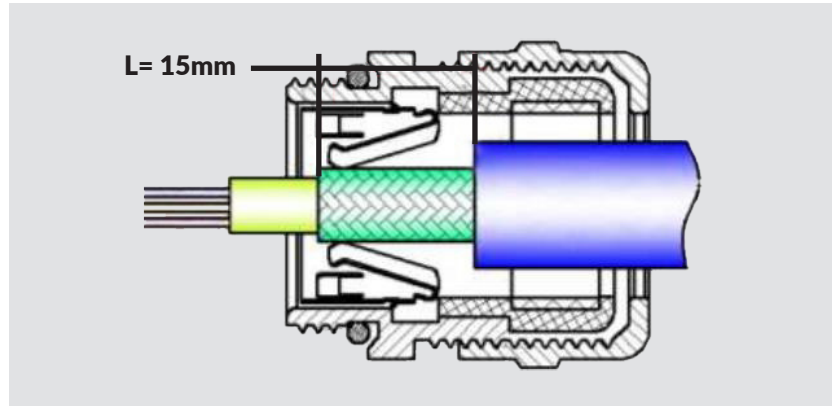

Figure 7

As shown in Figure 8 is the M63 gland with EMI function. In the connector installation, it is necessary to increase the shielding layer for the second part of the first step of stripping. The cut length of the shielding layer is about 38mm between the cable cut and the outside of the gland nut to ensure that the shielding layer can contact the shielding layer of the gland, as shown in Figure 9 below.

Note: The gland with EMI function used in the 5b terminal type is shown in Figure 8, and the length of L is 30mm.



Figure 8

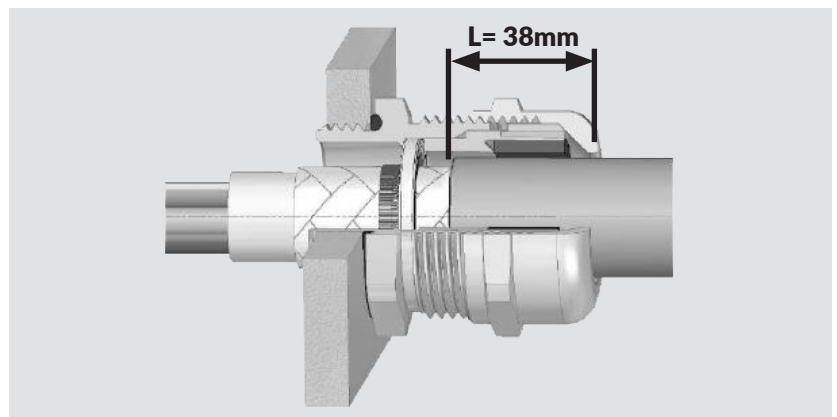

Figure 9

Appendix 1: Wind-Lok Coding Logic

Wind-Lok Code Logic

WL C 06 E RE 40 S W 7 M50 E
 1 2 3 4 5 6 7 8 9 10

WL: Wind-Lok Connector

1: Contact Style

C: Crimp Contact

2: Shell Style

03: Square Flange Receptacle

06: Stright Plug

3: Protection Cap

Omit: Does Not Include Protection Cap

E: Includes Protective Cap

3: Color Style

NC: No Color Coded Band Coating

BU: Blue Band Coat

OG: Orange Band Coat

YL: Yellow Band Coat

BN: Brown Band Coat

RD: Red Band Coat

WT: White Band Coat

GN: Green Band Coat

GY: Gray Band Coat

BK: Black Band Coat

5: Shell Size

32: Plug Shell Size 32

40: Plug Shell Size 40

6: Contact Style

S: Socket Contact

P: Pin Contact

7: Shell Key Rotation

N: 180° Normal Rotation, Slotted Plug Shell

W: 120° Alternate Rotation, Slotted Plug Shell

X: 90° Alternate Rotation, Slotted Plug Shell

Y: 210° Alternate Rotation, Slotted Plug Shell

J: 360° Rotation, No Keyways

8: Wire Style

1: 4/0 AWG - 120 SQ MM Crimp Wire Well

2: 262 KCMIL - 150 SQ MM Crimp Wire Well, Well Length is 1.150

2b: 262 KCMIL - 150 SQ MM Crimp Wire Well, Well Length is 1.500

3a: 313 KCMIL - 185 SQ MM Crimp Wire Well, Well Length is 1.150

3b: 313 KCMIL - 185 SQ MM Crimp Wire Well, Well Length is 1.500

3a: 313 KCMIL - 185 SQ MM Crimp Wire Well, Well Length is 1.150

4a: 373 KCMIL - 200 SQ MM Crimp Wire Well, Well Length is 1.150

4b: 373 KCMIL - 200 SQ MM Crimp Wire Well, Well Length is 1.500

5a: 444 KCMIL - 240 SQ MM Crimp Wire Well, Well Length is 1.150

5b: 444 KCMIL - 240 SQ MM Crimp Wire Well, Well Length is 1.500

6: 535 KCMIL Crimp Wire Well

7: 646 KCMIL Crimp Wire Well

7a: 300 SQ MM Crimp Wire Well

8: 777 KCMIL Crimp Wire Well

9+10: Thread and EMI Function

M40E: Use M40 Non-EMI Metal Cable Gland and Non-EMI Adapter

M50E: Use M50 Non-EMI Metal Cable Gland and Non-EMI Adapter

M63E: Use M63 Non-EMI Metal Cable Gland and Non-EMI Adapter

MM40M: Use M40 EMI Metal Cable Gland and EMI Adapter

MM50M: Use M50 EMI Metal Cable Gland and EMI Adapter

MM60M: Use M60 EMI Metal Cable Gland and EMI Adapter

Wind-Lok Part Number Logic

WL: Wind-Lok Connector

1: Contact Style

C=C

2: Shell Style

06=6

3: Protection Cap

Omit: N/A

E=E

4: Color Style

NC=0; BU=1; OG=2; YL=3; BN=4; RD=5; WT=6; GN=7; GY=8; BK=9

5: Shell Size

32=32

40=40

6+7: Contact Style+ Shell Key Rotation (Refer to 9-2437)

SN= S; SW= H; SX= J; SY= L; SJ=A; PN= N; PW= G; PX=I; PY= K; PJ= M

8: Wire Style

1=1, 2=2, 3a=3A, 3b= 3B, 4a=4A, 4b=4B, 5a=5A, 5b=5B, 6=6,

7=7, 7a=7A, 8=8

9+10: Thread and EMI Function

M40E=4E, M50E= 5E, M63E=6E;

MM40M=M4, MM50M=M5, MM63M=M6

Example: Code Numer: WLC06ERD40SW3bM50E

Paper Numer: CWLC6E540H3B5E

Appendix 2: Recommended Crimping Tools

KLAUKE HK60/22



Cross Section MM ²	Crimp Die Part Number
120	R22120
150	R22150
185	R22185
240	R22240
300	R22300

EIPRESS V1311 or V1311C

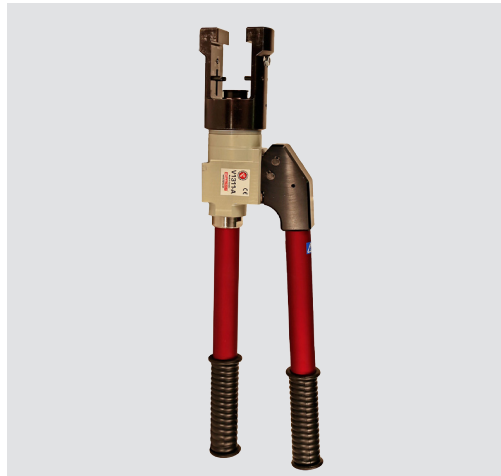

Cross Section MM ²	Crimp Die Part Number CAT 5	Crimp Die Part Number CAT 6
120	B19	B22
150	B22	B25
185	13B25	13B27
240	13B27	13B30
300	13B32	13B32

GREENLLE HK06FT



Crimp from 24SQMM (AWG4) up to 400SQMM (750MCM) - Die is Included with Tool.

Appendix 3: Recommended Torque for Connector Accessories

1. Recommended Torque for Adapter

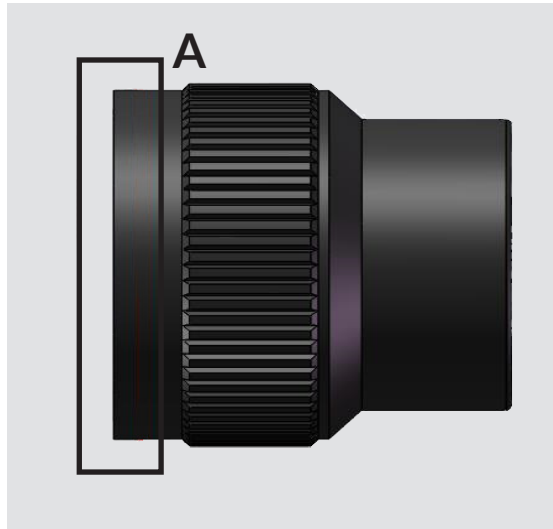

Connector Size	Thread at A	Recommended Torque (N · M)
32	1.8750-16UN	15.81-16.94
40	2.3125-16UNS	20.32-21.45

2. Torque at the Gland

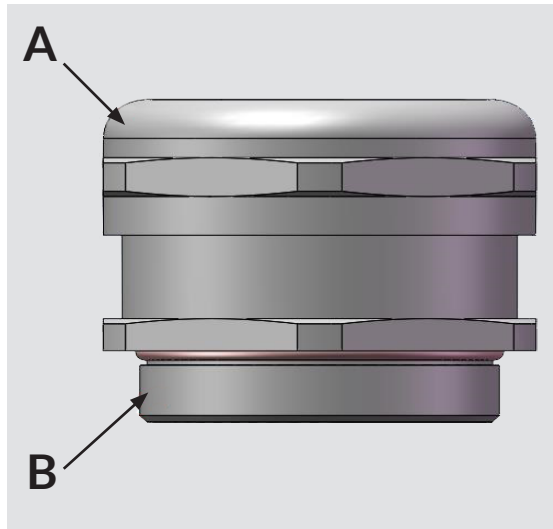

Gland Thread	No EMI		EMI	
	A (N · M)	B (N · M)	A (N · M)	B (N · M)
M40	18-22	18-22	TBD	TBD
M50	30-35	30-35	16-18	16-18
M60	TBD	TBD	20	20

Note: The 5b type contact uses the M50 gland with EMI function. The torque at A is 20N·M and the torque at B is 20N·M.

Appedix 4: Recommended Tightening Tools for Adapter

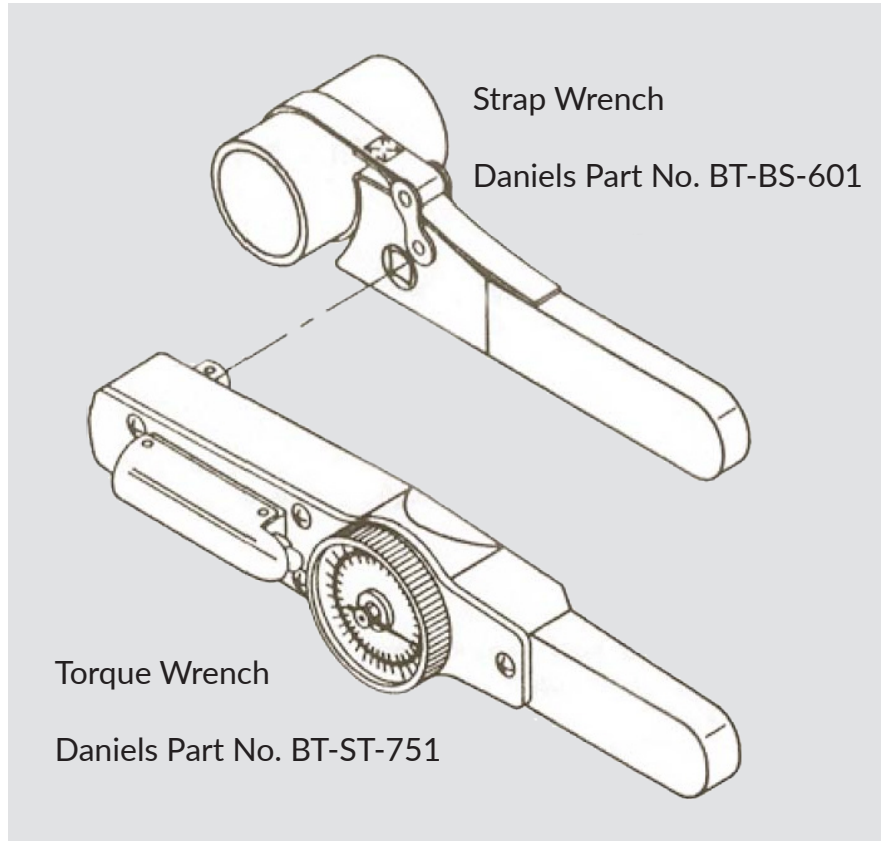

Appedix 5: Version Information

Version	Description	Date
A	Initial Release	2021/5/25