

# Amphenol®



## GTC-E Series

[www.amphenol-industrial.com](http://www.amphenol-industrial.com)

## Company Profile



*Endicott, NY*

### Amphenol Industrial Operations

Amphenol Industrial Operations, headquartered in a 30,000 square foot facility in Endicott, N.Y., provides a full range of high reliability power/signal connectors and interconnection systems specifically for the industrial markets including rail/mass transit, process control, automotive manufacturing, heavy equipment, wireless base stations and petrochemical/power generation.

Products include ruggedized-for-industry cylindrical, rectangular, fiber optic, signal and power, RADSOK power and power-to-board solutions, cable and harness assemblies, as well as industrialized versions of Amphenol's MIL-DTL-5015 cylindrical, MIL-DTL-26482 miniature cylindrical and GT reverse bayonet cylindrical connectors. Amphenol Industrial Operations employs more than 1,400 people globally and is ISO9001, TS96949 and MIL-STD-790 certified.



### Amphenol Technology (Zhuhai) Co., Ltd

Established in 2007, Amphenol Technology (Zhuhai) Co., Ltd. is a manufacturing facility for Amphenol Industrial Operations, which serves a number of industrial markets. Included but not limited to Factory Automation, Transportation, Heavy Equipment, Alternative Energy, Energy Storage. Server/Data Comm and Power Distribution.

Amphenol Technology (Zhuhai) Co., Ltd. covers an area of 276,000 ft<sup>2</sup> and is equipped with CNC, plating, injection molding and assembly workshops. This plant specializes in the design and manufacturing of industrial connectors featuring high power, high density, medium to high voltage electrical properties, and harsh environment applications.

With industry leading engineering, design and manufacturing expertise, Amphenol Technology(Zhuhai) Co., Ltd. has earned more than 60 utility patents on its innovative interconnects. Many of the products produced have been certified by independent standards including UL, IEC/TUV, ATEX, IECEx and MA. The facility is also certified to ISO 9001, ISO 14001 and IATF 16949.

## Table of Contents

<b>GTC-E Series</b>	<b>4</b>
Features .....	4
Targeted Applications .....	4
Specifications .....	4
<b>Insert Availability and Identification</b>	<b>5</b>
<b>How to Order</b>	<b>6</b>
<b>030</b>	<b>7</b>
Rear panel mount receptacle 030 .....	7
<b>030R</b>	<b>8</b>
Rear panel mount receptacle 030R .....	8
<b>030F</b>	<b>9</b>
Rear panel mount receptacle 030F .....	9
<b>02R</b>	<b>10</b>
Panel mount receptacle 02R .....	10
<b>06A</b>	<b>11</b>
Straight Plug 06A .....	11
<b>06 AMI/RMI</b>	<b>12</b>
Straight Plug 06 AMI/RMI .....	12
<b>06F</b>	<b>13</b>
Straight Plug 06F .....	13
<b>06R</b>	<b>14</b>
Straight Plug 06R .....	14
<b>Accessories</b>	<b>15</b>
97-3057 Style Cable Clamp .....	15
Receptacle Protection Caps .....	16
Plug Protection Caps .....	17
Sealing Gaskets .....	18
Cable Glands .....	19
Extraction Tool .....	20
<b>Panel Cut-Out Dimensions</b>	<b>21</b>

## GTC-E Series

GTC-E series is developed from Amphenol GT Series Reversed Bayonet Coupling Connectors. GTC-E series inherits most of the key features from GT series, which makes it fit for harsh environment. GTC-E series uses UL94-V0 hard plastic insert and removable contact. This new structure highly simplifies installation process and saves labor time. It perfectly fits for field installation and makes maintaining easier.

### Features

1/3 Turn Reverse Bayonet
Quick positive coupling
Audible and tactile indication of full coupling
High shock and vibration capabilities
Rugged construction
Crimp Termination
RADSOK socket contacts available
Operating Temperature: -40°C to +125°C
2000 Mating Cycles

### Targeted Applications

Industrial machinery
Material handling equipment
Rail/transit vehicles and system
Medical instrumentation & equipment
Communication equipment
HVAC
Commercial and building equipment
Lighting and signage
Agricultural machinery, recreational vehicles

### Specifications

Electrical Characteristics					
Rated Current	Contact Size	#0	#4	#8	#12
	Amperes	150A	80A	46A	23A
Radsok Current	Amperes	250A	120A	70A	35A
Rated Voltage	Refer to individual insert pattern				
Dielectric Withstanding Voltage	Refer to individual insert pattern				
Insulation Resistance	Refer to individual insert pattern				

Material and Mechanical	
Components	Material & Coating
Shell	Aluminum
Coupling Nut	Aluminum+
Contact	Copper alloy with silver or gold plating
Gasket	Neoprene rubber
Grommet	Neoprene rubber
Sealing O-Ring	Silicon rubber
Durability	2000 cycles
Contact Termination	Crimp

Environmental	
Waterproof Rating	IP67 & IP6K9K
Operating Temperature	-40°C to +125°C
Vibration	15g
Mechanical Shock	50G's

Certification	
UL In-Progress	

## Insert Availability and Identification

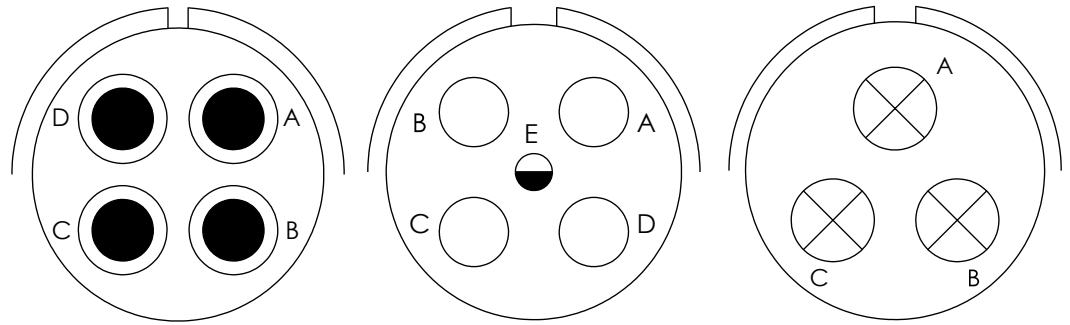

Insert Arrangement	22-22	32-XG		36-4
Contact Number	4	4	1	3
Contact Size	8	4	12	0

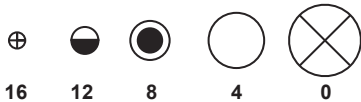

**CONTACT LEGEND**

16 12 8 4 0

\* Customer wire well options available, consult Amphenol for more information

Shell Size / Arrangement	Dielectric Withstanding Voltage	Dielectric Withstanding Voltage	Total Contacts	Contact Size			
				0	4	8	12
22-22	500VAC	2000VAC	4			4	
32-XG	500VAC	2000VAC	5		4		1
36-4	500VAC	2000VAC	3	3			

Application Cable Size	
Contact Size	Wire AVG
#0	0
#4	4
#8	8
#12	12

## Alternate Insert Positioning

Shell Size	Keyway	Degrees
22-22	W	80
	X	110
	Y	250
	Z	280
32-XG	W	80
	X	110
	Y	250
	Z	280
36-4	W	80
	X	110
	Y	250
	Z	280

To avoid cross-plugging problems in applications requiring the use of more than one connector of the same size and arrangement, alternate rotations are available as indicated in the accompanying charts. As shown in the diagram to the right, the front face of the pin insert is rotated within the shell in a clockwise direction from the normal shell key. The socket insert would be rotated counter-clockwise the same number of degrees in respect to the normal shell key.

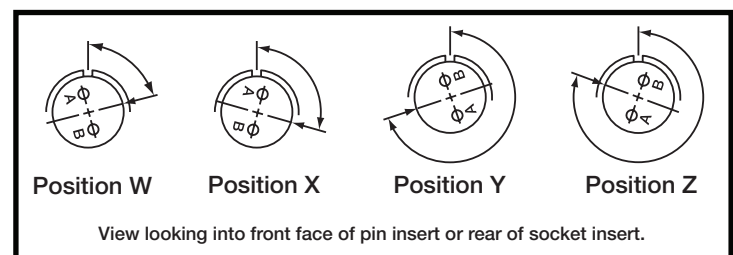

## How to Order

1	2	3	4/5	6	7	8	9
Series	Shell Size	Service Class	Shell Size & Insert Arrangement	Contact Style	Insert Rotation	Plating	Mod
GTCE	030	F	36-XG	P	W	(072)	(MXXP)

1. Series	
GTCE	Series and Contact Style

6. Contact Style	
P	Pin Contacts
S	Socket Contacts

2. Shell Style	
02	Box Mount Receptacle
030	Rear Panel Mount
06	Cable Plug

7. Insert Rotation	
No Letter is Required for Normal Position	
W	
X	
Y	
Z	

3. Service Class	
A	Accessory adapter
F	Clamp with individual sealing grommet (36-4 insert only).
R	(02) No thread, no accessory, environmental with panel sealing gasket
	Adapter with individual wire sealing grommet
AMI	Metric adapter for cable glands
RMI	Metric adapter for cable glands and environmental grommet

8. Plating	
(023)	Electroless Nickel
(025)	Black Zinc Cobalt
(072)	Conductive Gray Zinc Nickel

4/5. Shell Size & Insert Arrangement	
22-22	
32-XG	
36-4	

9. Mod	
MXXP*	AMI & RMI Class Only
MXXM*	AMI & RMI Class Only

\*Consult page #23 for cable gland options

# 030

## Rear panel mount receptacle 030

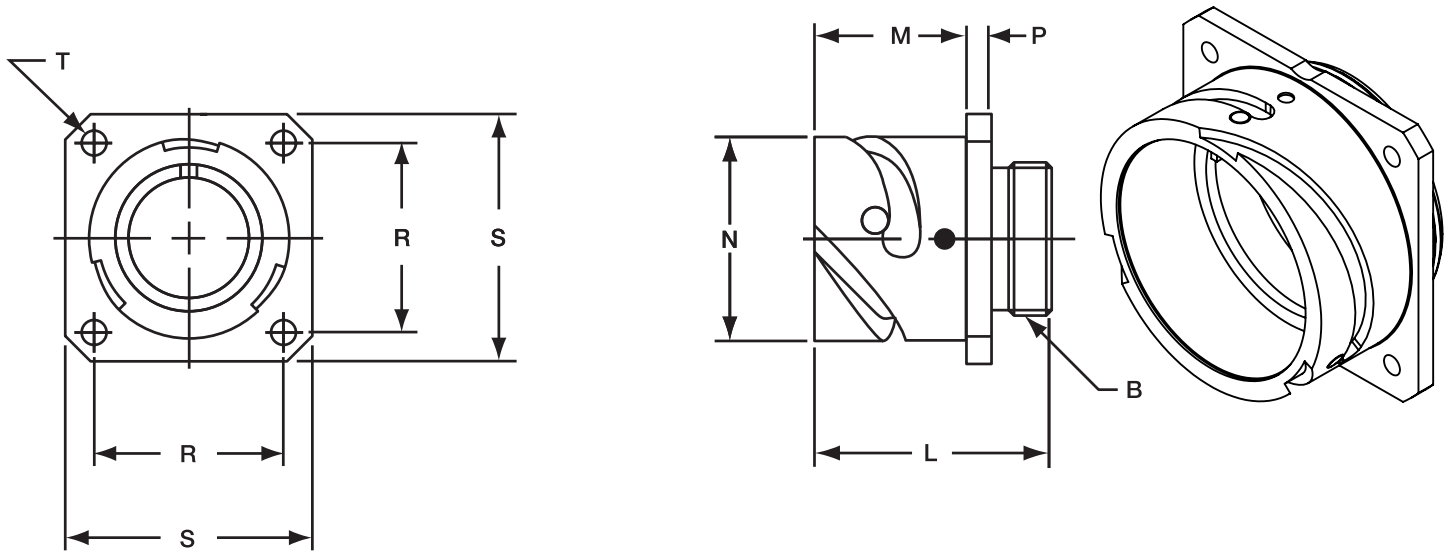

Table 1: Inches

Shell Size	B Thread Class 2A	L ± .012	M	+ .016 - .000	N	+ .000 - .006	P ± .008	R ± .004	S ± .012	T	+ .004 - .000
22	1.2500-18UNEF	1.331	.947		1.472		.157	1.252	1.614	.126	
32	1.8750-16UN	1.469	.947		2.102		.157	1.752	2.244	.169	
36	2.0625-16UN	1.469	.947		2.346		.157	1.937	2.500	.169	

Table 2: Millimeters

Shell Size	B Thread Class 2A	L ± 0.30	M	+ 0.016 - 0.000	N	+ 0.000 - 0.006	P ± 0.008	R ± 0.004	S ± 0.012	T	+ 0.004 - 0.000
22	1.2500-18UNEF	33.8	23.05		37.4		4.0	31.8	41.0	3.2	
32	1.8750-16UN	37.3	24.05		53.4		4.0	44.5	57.0	4.3	
36	2.0625-16UN	37.3	24.05		59.6		4.0	49.2	63.5	4.3	

# 030R

## Rear panel mount receptacle 030R

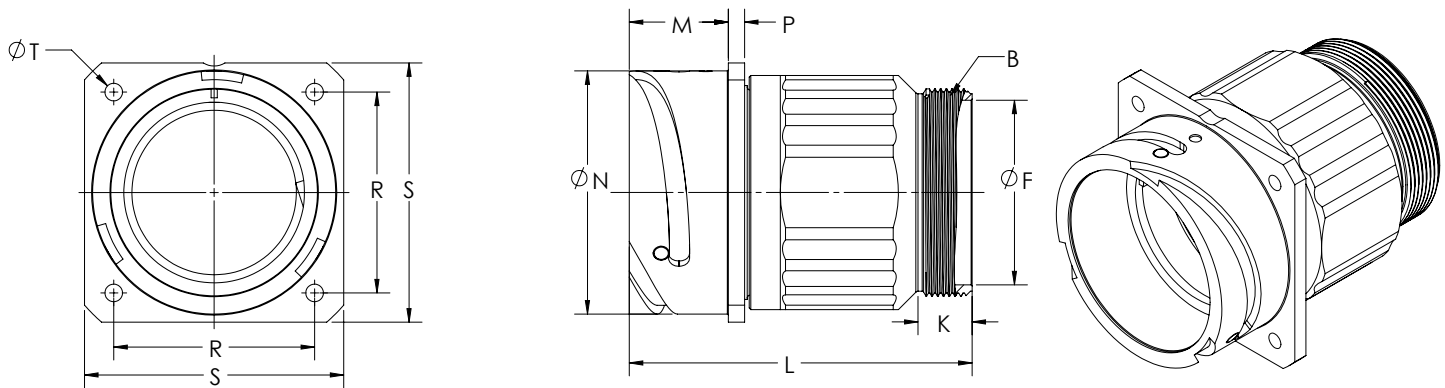

Table 1: Inches

Shell Size	B Thread Class 2A	F Min.	K Min.	L Max.	M	+ .016 - .000	N	+ .000 - .006	P ± .008	R ± .004	S ± .012	T	+ .004 - .000
22	1.2500-18UNEF	.965	.374	2.362	.907		1.472		.157	1.252	1.614	.126	
32	1.8750-16UN	1.488	.433	2.560	.947		2.102		.157	1.752	2.244	.169	
36	2.0625-16UN	1.780	.465	3.150	.947		2.346		.157	1.937	2.500	.169	

Table 2: Millimeters

Shell Size	B Thread Class 2A	F Min.	K Min.	L Max.	M	+ 0.40 - 0.00	N	+ 0.00 - 0.15	P ± 0.20	R ± 0.1	S ± 0.3	T	+ 0.1 - 0.0
22	1.2500-18UNEF	24.5	9.5	60	23.05		37.4		4.0	31.8	41.0	3.2	
32	1.8750-16UN	37.8	11.0	65	24.05		53.4		4.0	44.5	57.0	4.3	
36	2.0625-16UN	45.2	11.8	80	24.05		59.6		4.0	49.2	63.5	4.3	



# 030F

## Rear panel mount receptacle 030F

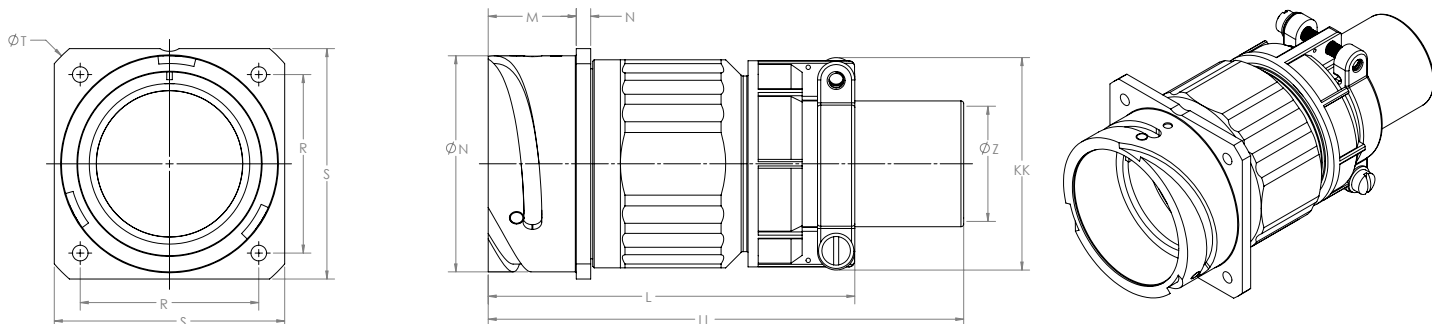

Table 1: Inches

Shell Size	M	+ .016 - .000	N	+ .000 - .006	P ± .008	R ± .004	S ± .012	T	+ .004 - .000	Z Nominal	KK Max.	LL Max.
22	.907		1.472		.157	1.252	1.614	.126		.625	1.476	4.921
32	.947		2.102		.157	1.752	2.244	.169		.937	2.035	4.921
36	.947		2.346		.157	1.937	2.500	.169		1.250	2.283	5.315

Table 2: Millimeters

Shell Size	M	+ 0.40 - 0.00	N	+ 0.00 - 0.15	P ± 0.20	R ± 0.1	S ± 0.3	T	+ 0.1 - 0.0	Z Nominal	KK Max.	LL Max.
22	77		23.05		4.0	31.8	41.0	3.2		15.87	37.5	125
32	85		24.05		4.0	44.5	57.0	4.3		23.79	51.7	125
36	105		24.05		4.0	49.2	63.5	4.3		31.75	58.0	135

# 02R

## Panel mount receptacle 02R

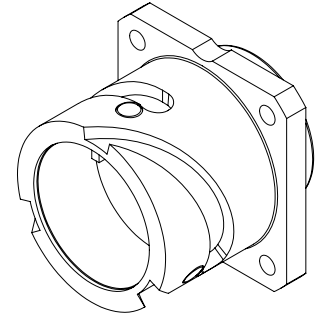
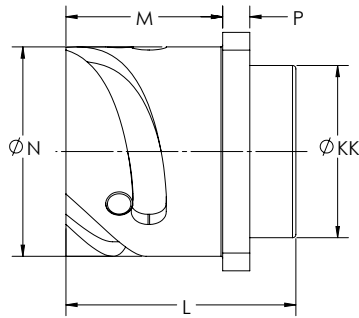
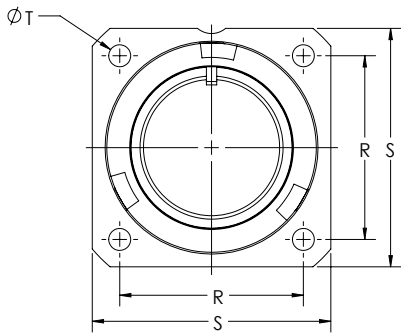

Table 1: Inches

Shell Size	M	+ .016 - .000	N	+ .000 - .006	P ± .008	R ± .004	S ± .012	T	+ .004 - .000	L ± .012	KK Max.
22	.907		1.472		.157	1.252	1.614	.126		1.331	1.268
32	.947		2.102		.157	1.752	2.244	.169		1.469	1.882
36	.947		2.346		.157	2.500	2.500	.169		1.469	2.063

Table 2: Millimeters

Shell Size	M	+ 0.016 - 0.000	N	+ 0.000 - 0.006	P ± 0.008	R ± 0.004	S ± 0.012	T	+ 0.004 - 0.000	L ± 0.012	KK Max.
22	23.0		37.4		4.0	31.8	41.0	3.2		33.8	32.2
32	24.1		53.4		4.0	44.5	57.0	4.3		37.3	47.8
36	24.1		59.6		4.0	49.2	63.5	4.3		37.3	52.4

# 06A

## Straight Plug 06A

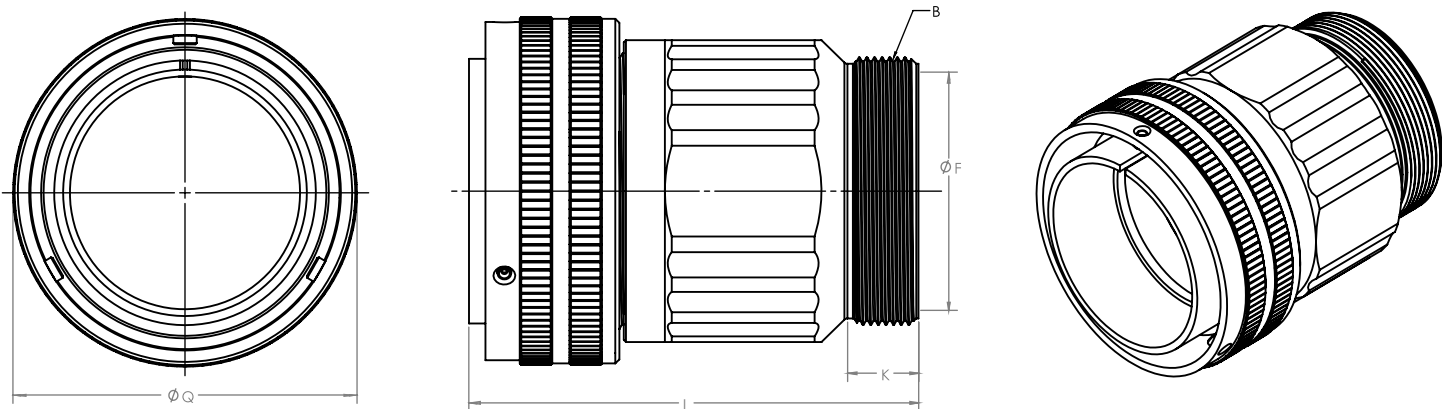

Table 1: Inches

Shell Size	B Thread Class 2A	F Min.	K Min.	L Max.	Q Max.
22	1.1875-18UNEF	.965	.374	2.362	1.697
32	1.7500-18UNS	1.488	.433	2.560	2.366
36	2.0000-18UNS	1.780	.465	3.150	2.610

Table 2: Millimeters

Shell Size	B Thread Class 2A	F Min.	K Min.	L Max.	Q Max.
22	1.1875-18UNEF	24.50	9.5	60	43.1
32	1.7500-18UNS	37.8	11.0	65	60.1
36	2.0000-18UNS	45.2	11.8	80	66.3

# 06 AMI/RMI

## Straight Plug 06 AMI/RMI

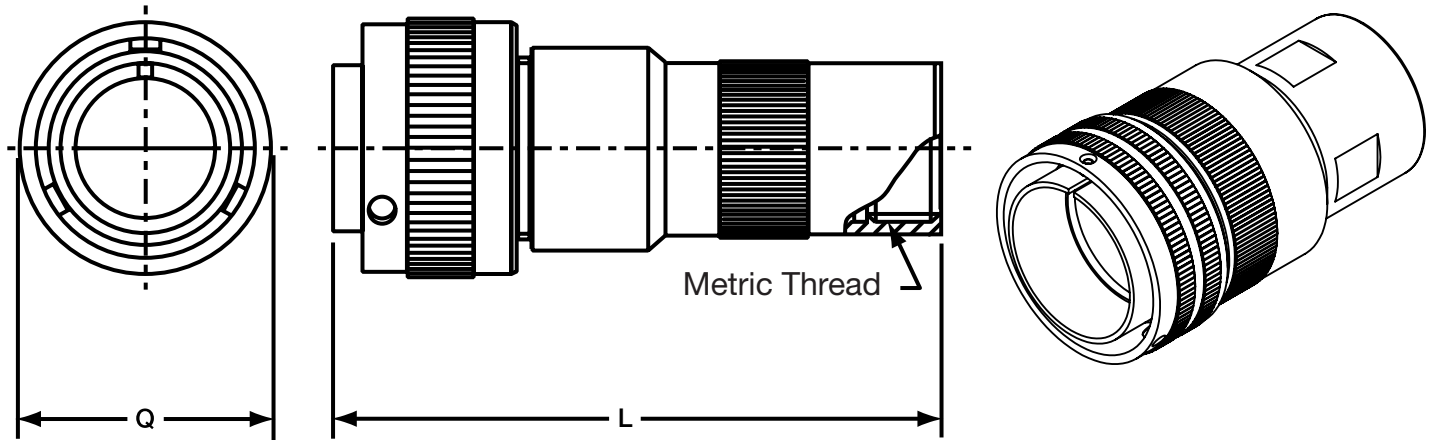

Table 1: Inches

Shell Size	L Ref.	Q Max.
22	3.395	1.697
32	3.751	2.366
36	3.795	2.610

Table 2: Millimeters

Shell Size	L Ref.	Q Max.
22	86.2	43.1
32	95.3	60.1
36	96.4	66.3

\*Consult Page #19 for cable gland options

# 06F

## Straight Plug 06F

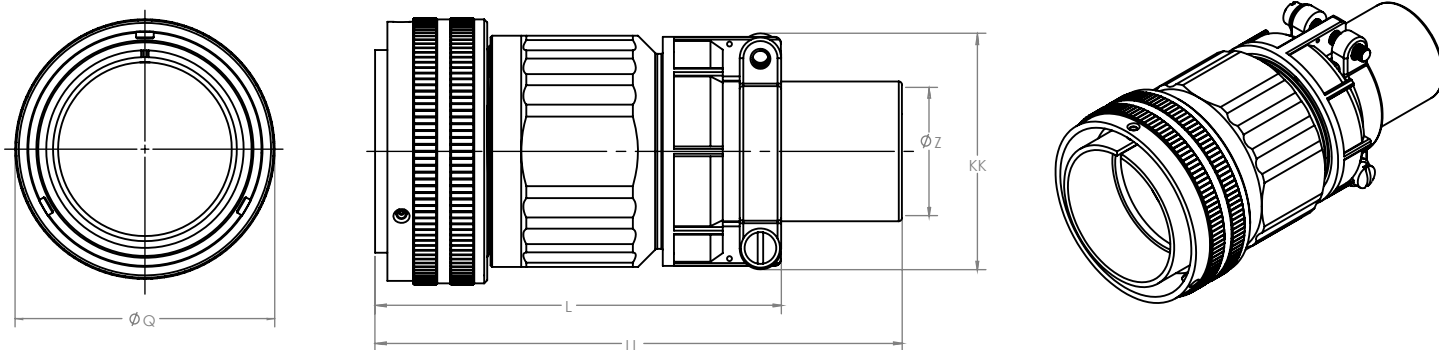

Table 1: Inches

Shell Size	L Ref.	Q Max.	Z Nominal	KK Max.	LL Max.
22	2.953	1.697	.625	1.476	4.921
32	3.543	2.366	.937	2.035	4.921
36	3.937	2.610	1.250	2.283	5.315

Table 2: Millimeters

Shell Size	L Ref.	Q Max.	Z Nominal	KK Max.	LL Max.
22	75	43.1	15.87	15.87	125
32	90	60.1	23.79	51.7	125
36	100	66.3	31.75	58.0	135

# 06R

## Straight Plug 06R

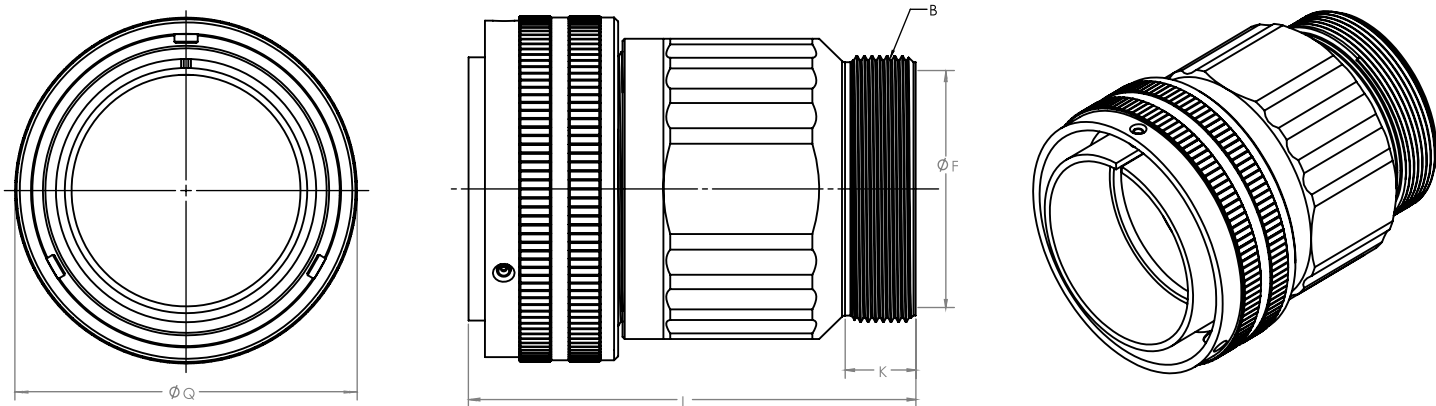

Table 1: Inches

Shell Size	B Thread Class 2A	F Min.	K Min.	L Max.	Q Max.
22	1.1875-18UNEF	.965	.374	2.362	1.697
32	1.7500-18UNS	1.488	.433	2.560	2.366
36	2.0000-18UNS	1.780	.465	3.150	2.610

Table 2: Millimeters

Shell Size	B Thread Class 2A	F Min.	K Min.	L Max.	Q Max.
22	1.1875-18UNEF	24.5	9.5	60	43.1
32	1.7500-18UNS	37.8	11.0	65.80	60.1
36	2.0000-18UNS	45.2	11.8	31.75	66.3

## Accessories

### 97-3057 Style Cable Clamp

- Concentric cable clamps, insure strain relief and central location of the cable
- Can be used with bushing 9779-513-XX

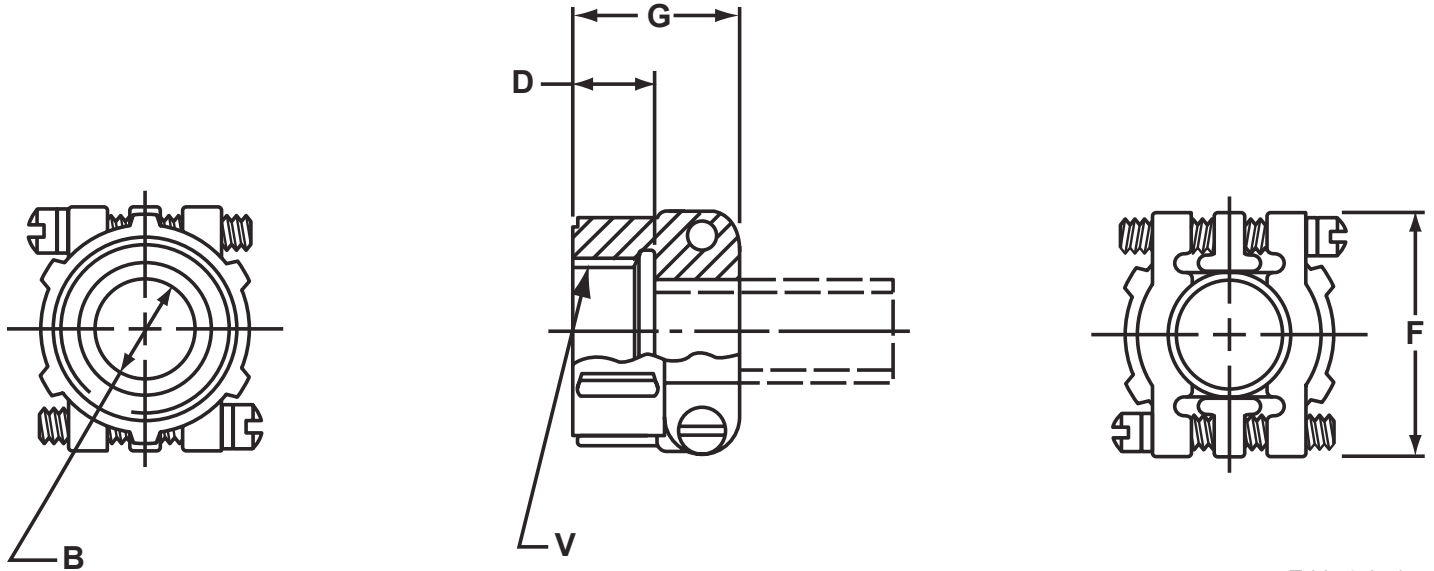

Table 1: Inches

Part Number	Used with shell size	Used with bushing	B	D	G	F	V thread Class 2B
97-3057-1012	20-22	9779-513-12	.758	.395	.945	1.475	1.1875-18UNEF
97-3057-1020	32	9779-513-20	1.256	.460	1.094	2.055	1.7500-18UNS
97-3057-1024	36	9779-513-24	1.380	.520	1.157	2.265	2.0000-18UNS

Table 2: Millimeters

Part Number	Used with shell size	Used with bushing	B	D	G	F	V thread Class 2B
22	20-22	9779-513-12	19.2	10.0	24.0	37	1.1875-18UNEF
32	32	9779-513-20	31.9	11.7	27.8	52	1.7500-18UNS
36	36	9779-513-24	35.0	13.2	29.4	58	2.0000-18UNS

## Accessories

### Receptacle Protection Caps

- Protective metal caps which seal the front of receptacles
- Includes a chain for retention of the cap at the required location
- All GT receptacles

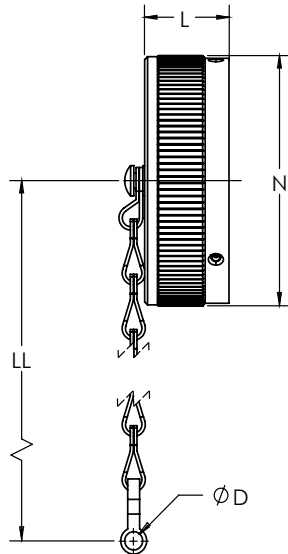

\*10-580902

To complete order number, add shell size and plating suffix number. For example, shell size 32 with Gray Zinc Nickel plating would be 10-580902-32FL.

Table 1: Inches

Part Number	Shell Size	D	+ 0.020 - 0.000	L Max.	N Max.	LL Approx.
10-580902-22( )	22	.173		.900	1.713	5.000
10-580902-32( )	32	.261		.900	2.372	7.480
10-580902-36( )	36	.261		.900	2.638	7.480

Table 2: Millimeters

Part Number	Shell Size	D	+ 0.020 - 0.000	L Max.	N Max.	LL Approx.
10-580902-22( )	22	4.4		22.9	43.5	127
10-580902-32( )	32	5.6		22.9	60.5	190
10-580902-36( )	36	5.6		22.9	67	175

Plating Type	Plating Suffix
Electroless nickel	-XXG
Black zinc cobalt	-XXY
Gray zinc nickel	-XXFL



## Accessories

### Plug Protection Caps

- Protective metal caps which seal the front of plugs
- Includes a chain for retention of the cap at the required location
- All GT plugs

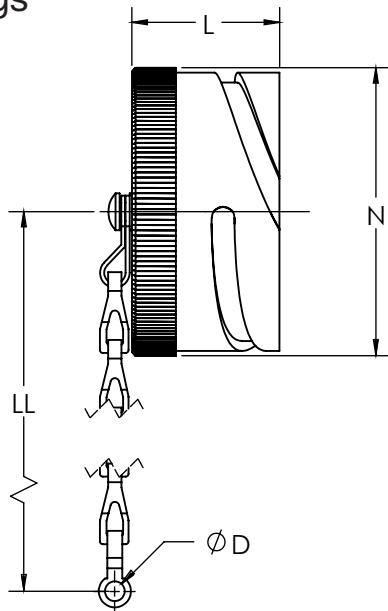

\*10-580903

To complete order number, add shell size and plating suffix number. For example, shell size 32 with Gray Zinc Nickel plating would be 10-580903-32FL.

Table 1: Inches

Part Number	Shell Size	D	+ .020 - .000	L Max.	N Max.	LL Approx.
10-580903-22( )	20	.189		1.260	1.563	5.520
10-580903-32( )	32	.261		1.260	2.193	7.480
10-580903-36( )	36	.261		1.260	2.437	7.480

Table 2: Millimeters

Part Number	Shell Size	D	+ 0.020 - 0.000	L Max.	N Max.	LL Approx.
10-580903-22( )	20	4.8		32	39.7	140
10-580903-32( )	32	5.6		32	55.7	190
10-580903-36( )	36	5.6		32	61.9	175

Plating Type	Plating Suffix
Electroless nickel	-XXG
Black zinc cobalt	-XXY
Gray zinc nickel	-XXFL

# Accessories

## Sealing Gaskets

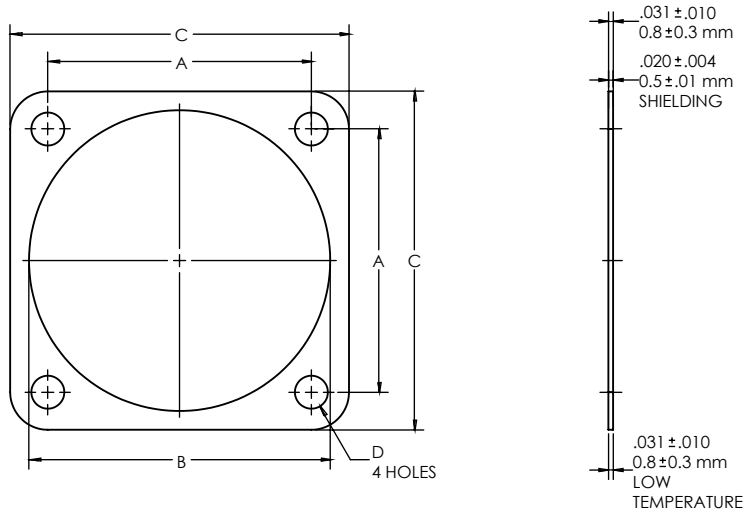

**PLAIN FLAT GASKET** The Amphenol plain flat gasket of synthetic rubber material is provided to take complete advantage of waterproof and pressure sealing features. It is for use with the flange mounted receptacle. Consult Amphenol Industrial Operations, Sidney NY, for further information.

Order Data for Panel Mount Gaskets	
Front Panel Plain Version	Rear Panel Plain Version
10-040450-022	10-580649-022
10-040450-032	10-580649-032
10-040450-036	10-580649-036

Table 1: Inches

Installation Dimensions								
Shell Size	A ± 0.010	Front Panel B	+ .016 - .000	Rear Panel B	+ .016 - .000	C	+ .016 - .000	D ± .010
22	20	1.250		1.480		1.625		.203
32	32	2.000		2.110		2.250		.219
36	36	2.188		2.354		2.500		.219

Table 2: Millimeters

Installation Dimensions								
Shell Size	A ± 0.20	Front Panel B	+ 0.40 - 0.00	Rear Panel B	+ 0.40 - 0.00	C	+ 0.40 - 0.00	D ± 0.010
22	31.8	34.90		37.60		41.20		5.15
32	44.5	50.80		53.60		57.20		5.56
36	49.2	55.57		59.80		63.50		5.56

# Accessories

## Cable Glands

Nylon Cable Glands			
Material	Nylon 66 (UL Approved 94V-2)		
Seal Ring	UL 94V-2 (UL Approved 94V-2)		
Thread Type	Metric		
Temp Range	Static:	Dynamic	Short Term
	- 40°C ~ +100°C	- 20°C ~ + 80°C	+120°C
Colors	Gray, Black		

Metal Cable Glands	
Material	Brass with Nickel; Brass with Tin/Nickel
Clamping	UL approved PA6, 94V-0
Seal Ring	UL 94V-2 (UL Approved 94V-2)
Thread Type	Metric
Protective	IP68 (tighten with o-ring)
Temp Range	- 40°C ~ +100°C
M12, M16, M20 are UL recognized under file # E339605	

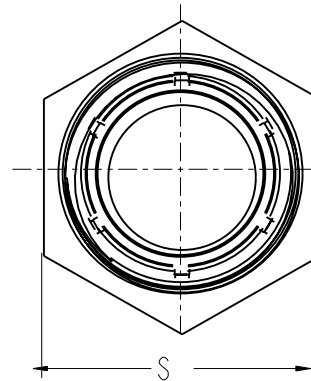
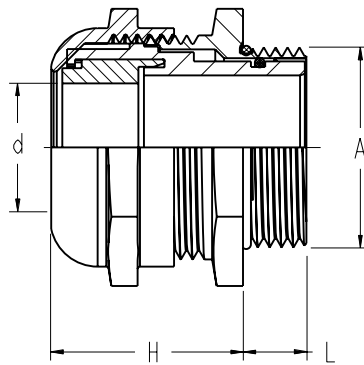

Nylon Cable Glands						
AIO Part	Thread "A"	Max "d" (mm)	Cable Range (mm)	Thread "L" (mm)	Clamp "H" (mm)	Spanner "S" (mm)
AIO-CSM12	M12x1.5	8	3 – 6.5	8	20	15
AIO-CSM16	M16x1.5	8	4 – 8	8	22	19
AIO-CSM18	M18x1.5	10	5 – 10	9	25	22
AIO-CSM20	M20x1.5	12	6 – 12	9	30	24
AIO-CSM22	M22x1.5	14	10 – 14	10	30	27
AIO-CSM24	M24x1.5	14	10 – 14	10	30	27
AIO-CSM25	M25x1.5	18	13 – 18	10	30	33
AIO-CSM30	M30x2.0	18	13 – 18	11	33	33
AIO-CSM32	M32x1.5	25	18 – 25	11	38	42
AIO-CSM33	M33x2.0	25	18 – 25	11	39	42
AIO-CSM40	M40x1.5	32	22 – 32	13	48	54
AIO-CSM50	M50x1.5	38	32 – 38	14	50	60
AIO-CSM72	M72x2.0	57	51 – 57	16	75	80

Metal Cable Glands						
AIO Part	Thread "A"	Max "d" (mm)	Cable Range (mm)	Thread "L" (mm)	Clamp "H" (mm)	Spanner "S" (mm)
AIO-CSJM12	M12x1.5	6.5	3 – 6.5	6.2	15	14
AIO-CSJM14	M14x1.5	8	4 – 8	5	19	15
AIO-CSJM16	M16x1.5	9	6 – 9	6.3	20	18
AIO-CSJM18	M18x1.5	10	5 – 10	7	20	22
AIO-CSJM20	M20x1.5	12	6 – 12	8.3	20	22
AIO-CSJM22	M22x1.5	14	10 – 14	8	24	24
AIO-CSJM24	M24x1.5	14	10 – 14	8	24	27
AIO-CSJM25	M25x1.5	18	13 – 18	7.8	23	30
AIO-CSJM27	M27x2.0	18	13 – 18	8	26	30
AIO-CSJM30	M30x2.0	18	13 – 18	8	26	32
AIO-CSJM32	M32x1.5	25	18 – 25	10	27	40
AIO-CSJM36	M36x2.0	25	18 – 25	10	34	40
AIO-CSJM40	M40x1.5	32	22 – 32	10	39	50
AIO-CSJM50	M50x1.5	38	32 – 38	11	39	60
AIO-CSJM63	M63x1.5	44	37 – 44	12	43	67
AIO-CSJM72	M72x2.0	52	46 – 52	16	47	75
AIO-CSJM80	M80x2.0	60	52 – 60	20	57	90
AIO-CSJM90	M90x2.0	70	62 – 70	20	57	100

# Accessories

## Extraction Tool

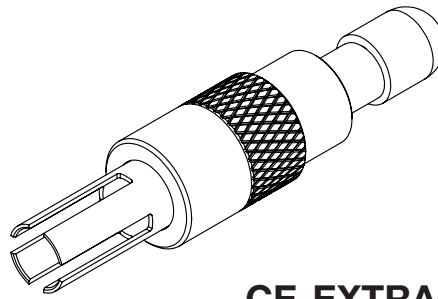

**CE-EXTRACT-00**



### Material

Contact body: Cooper alloy  
 Retaining clip: Plastic  
 Surface coating: Silver

1		2		3		4		5		6	
CE		-10		P		-4		-1		-50	
Contact Type		Contact Size		Gender		Crimp Range		Plating		Packing	
CE	Crimp	0	Size 0 awg	P	Male Contact	0	0 awg	1	Silver	Omit for single contact	
		4	Size 4 awg	S	Female Contact	4	4 awg			50	Bulk 50 pcs
		8	Size 8 awg	R	Female RADSOK Contact	8	8 awg	5	Gold 30u"	100	Bulk 100 pcs
		12	Size 12 awg			12	12-14 awg			500	Bulk 500 pcs

\*Consult Amphenol for custom wire well

# Panel Cut-Out Dimensions

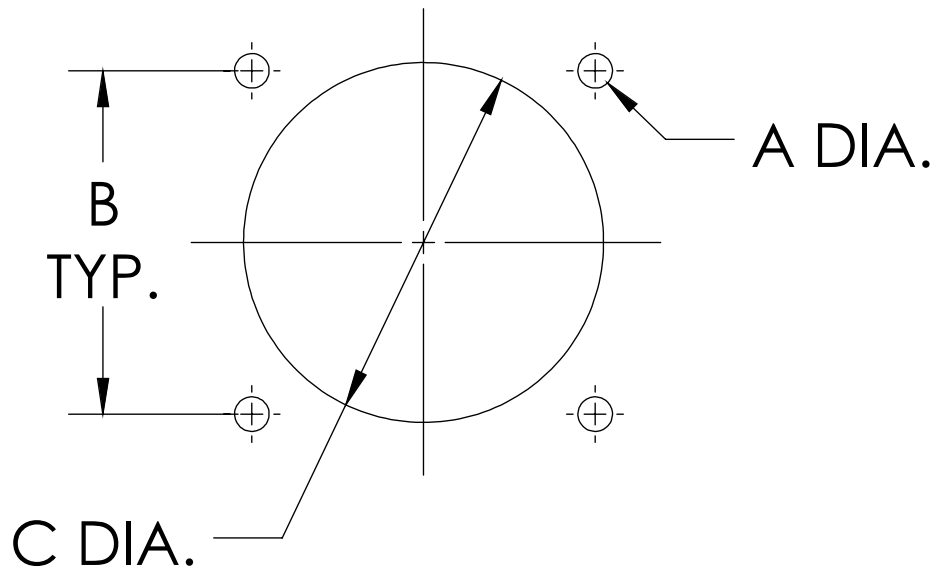

Table 1: Inches

Shell Size	A Dia. Hole	Connector Style		
		02,030	Front Mount 02	Front Mount 030
		B ± .004	C Dia.	C Dia.
22	20	1.252	1 5/16	1 1/2
32	32	1.752	1 15/16	2 1/8
36	36	1.937	2 1/8	2 3/8

Table 2: Millimeters

Shell Size	A Dia. Hole	Connector Style		
		02,030	Front Mount 02	Front Mount 030
		B ± 0.1016	C Dia.	C Dia.
22	20	31.80	33.34	38.10
32	32	44.50	49.21	53.98
36	36	49.20	53.98	60.33



**AMPHENOL CORPORATION**  
**Amphenol Industrial**  
**Operations**

Phone: 888-364-9011  
20 Valley Street  
Endicott, NY 13760-3600  
[www.amphenol-industrial.com](http://www.amphenol-industrial.com)

**Amphenol Technology(Zhuhai) Co., Ltd.**

No.63, Xinghan Road, Sanzao Town,  
Jinwan, Zhuhai, 519040  
China Tel: +86-756-398 9725  
Fax: +86-756-398 9768  
[www.amphenol-industrial.com](http://www.amphenol-industrial.com)  
Email: [tech@amphenol-aio.com](mailto:tech@amphenol-aio.com)